

PLAN

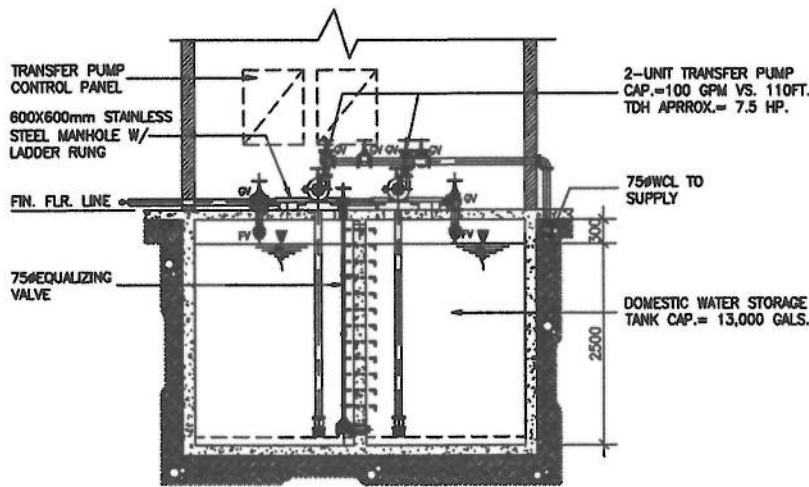

SECTION - 'A'

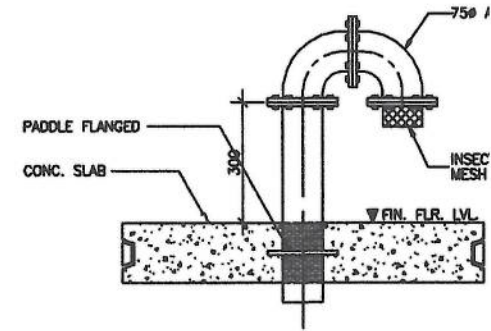

(IN R.C. SLAB)
DETAIL OF AIRVENT P

2
P 1 SCALE N D

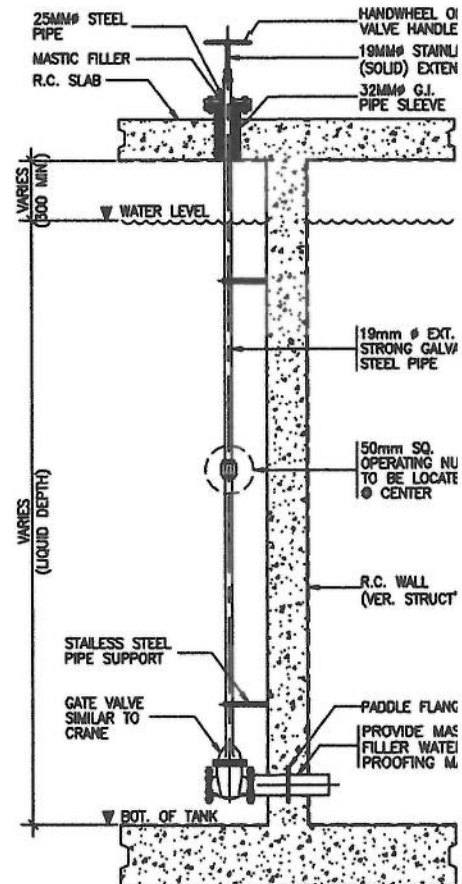

3
P 1 SCALE N D

1
P 1 SCALE N D T S

DETAIL OF DOMESTIC WATER STORAGE TANK



COMMISSION ON HIGHER EDUCATION
C.P. Garcia Ave., U.P. Dillman Campus,
Dillman, Quezon City

DRAWN AND PREPARED BY:

Engr. Jaime N. Aquino, Jr.
ENGR. JAIME N. AQUINO, JR.
PTS-III, GSD-AFMS

RECOMMENDING APPROVAL:

Engr. Juan F. Purinan, Jr.
ENGR. JUAN F. PURINAN, JR.
CHIEF ADMIN. OFFICER, GSD-AFMS

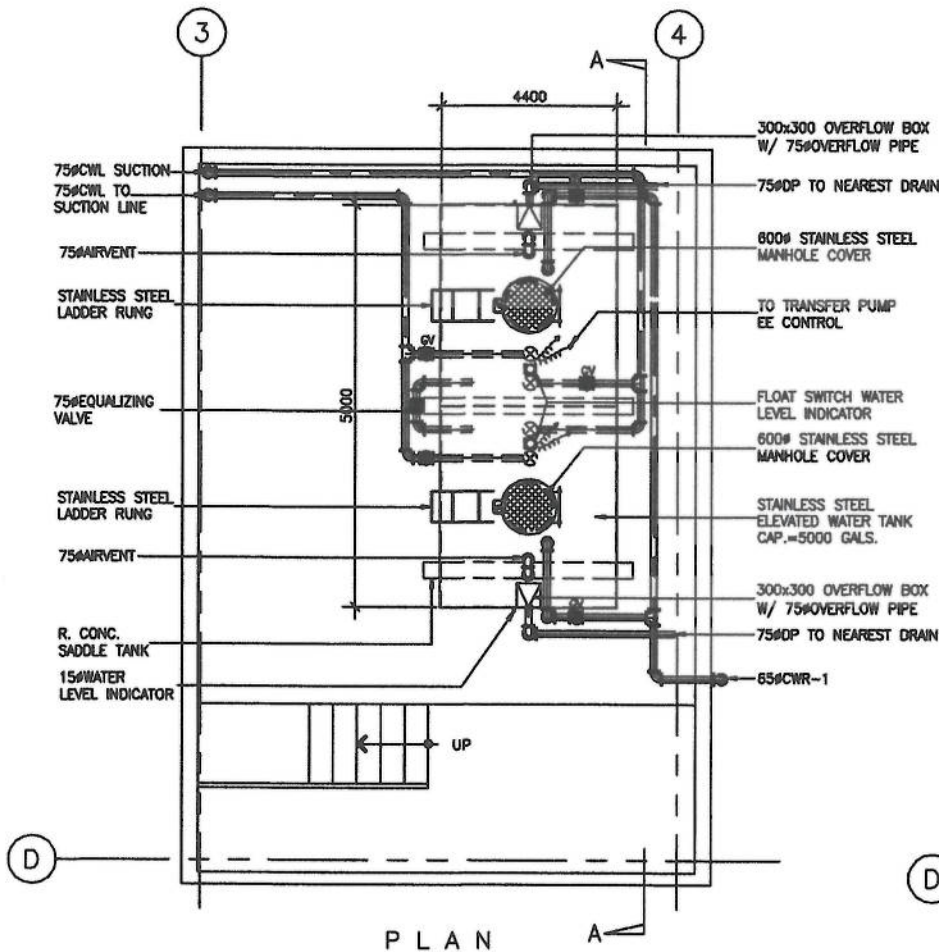

P L A N

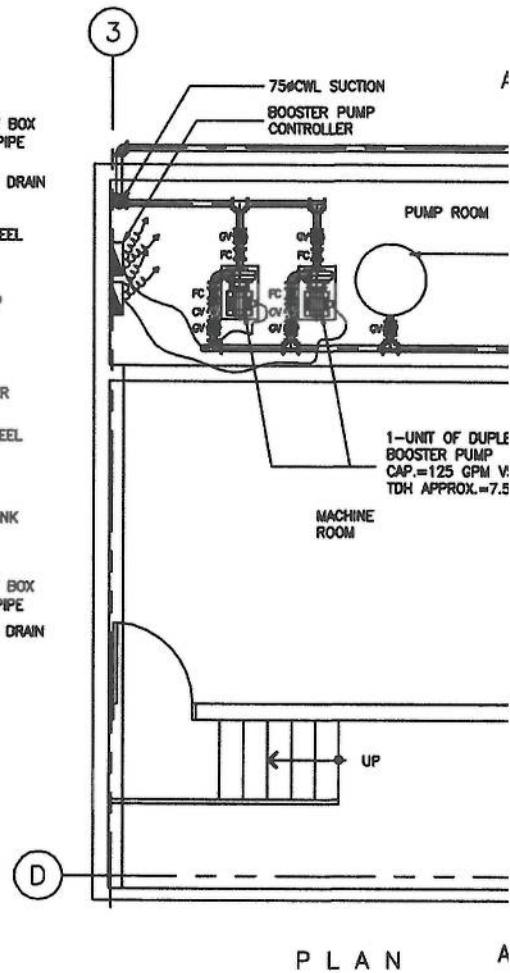

P L A N

1 DETAIL OF ELEVATED
P 2 SCALE



COMMISSION ON HIGHER EDUCATION
C.P. Garcia Ave., U.P. Diliman Campus,
Diliman, Quezon City

DRAWN AND PREPARED BY:

Jaime N. Aquino, Jr.
ENGR. JAIME N. AQUINO, JR.
PTS-III, GSD-AFMS

RECOMMENDING APPROVAL:

Juan F. Puriran, Jr.
ENGR. JUAN F. PURIRAN, JR.
CHIEF ADMIN. OFFICER, GSD-AFMS

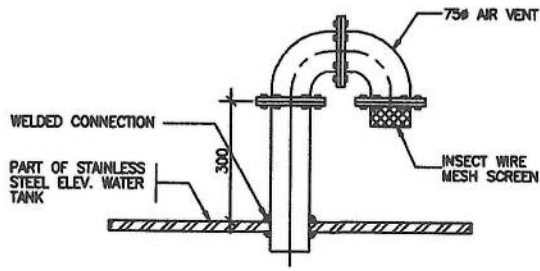

(IN STAINLESS STEEL)
1 DETAIL OF AIRVENT PIPE
 SCALE N D T S

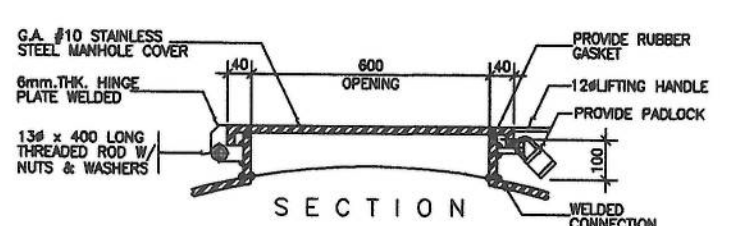
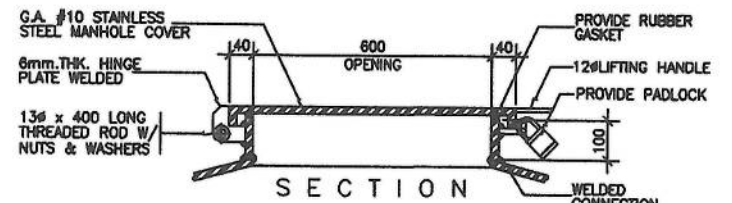
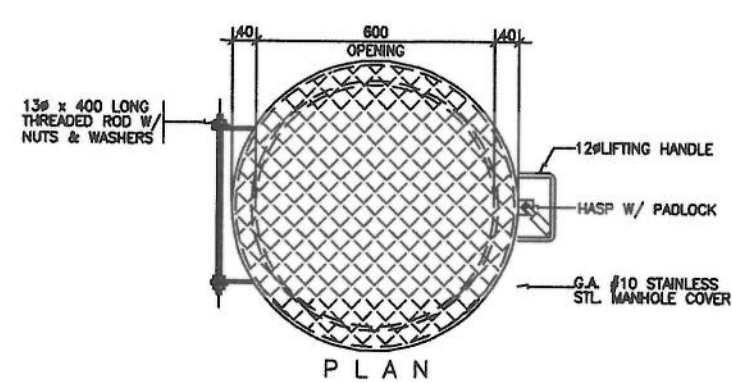

DETAIL OF MANHOLE COVER
 (FOR STAINLESS STEEL WATER TANK)
2 SCALE N D T S

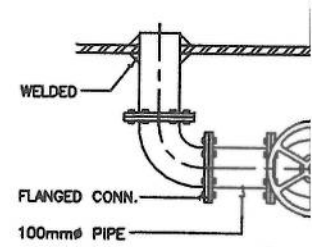
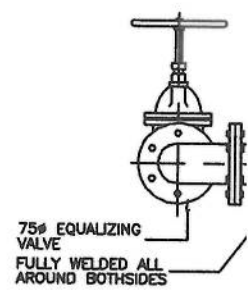

3 DETAIL OF EQUAL
 STAINLESS STEEL
 SCALE

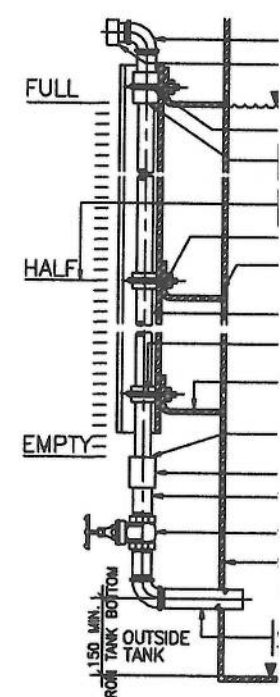

4 WATER LEVEL
 SCALE



COMMISSION ON HIGHER EDUCATION
 C.P. Garcia Ave., U.P. Diliman Campus,
 Diliman, Quezon City

DRAWN AND PREPARED BY:

Jaime N. Aquino, Jr.
ENGR. JAIME N. AQUINO, JR.
 PTS-III, GSD-AFMS

RECOMMENDING APPROVAL:

Juan F. Puriran, Jr.
ENGR. JUAN F. PURIRAN, JR.
 CHIEF ADMIN. OFFICER, GSD-AFMS